



# Z874-21-HDG

SPECIFICATION SHEET

## 21 [533] WIDE THROAT TRENCH DRAIN SYSTEM W/ HEAVY-DUTY GALVANIZED FRAME

TAG \_\_\_\_\_

Dimensional Data (inches and [ mm ]) are Subject to Manufacturing Tolerances and Change Without Notice

SPECIFYING ENGINEER IS RESPONSIBLE FOR CONCRETE ENCASEMENT AND REINFORCING BASED UPON APPLICATION AND LOCAL CODES

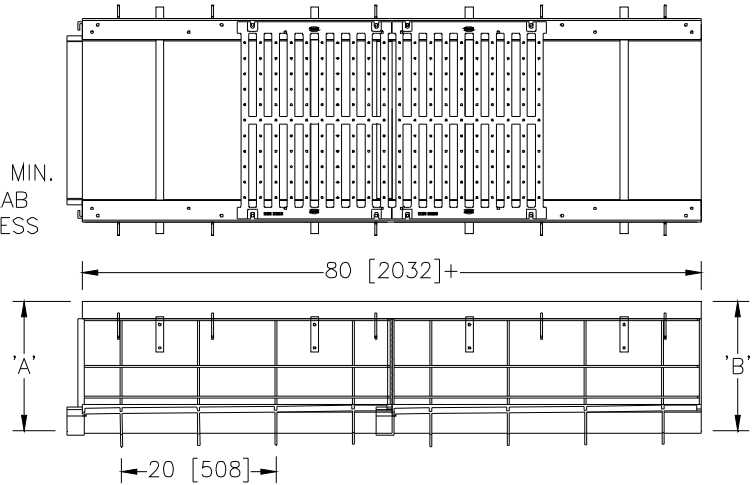
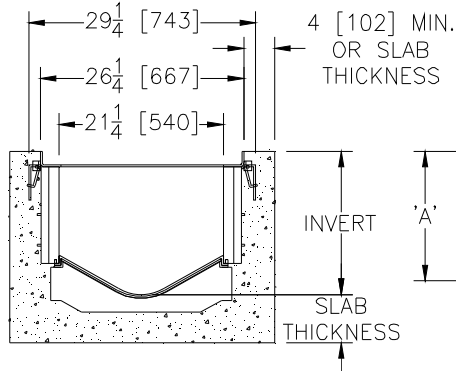

+Actual High Density Polyethylene channel length is 82 [2083] to allow for overlap, with frame attached the length is 84-1/2 [2146] with the exception of P.N. 2101P and 2130P.

**ENGINEERING SPECIFICATION:** Zurn Z874-21-HDG Channels shall be 80 [2032] long, 26-1/4 [667] wide reveal and have a 21 [533] wide throat. Modular channel sections shall be made of 0% water absorbent High Density Polyethylene (HDPE). Shall have a positive mechanical connection between channel sections that will not separate during the installation and shall mechanically lock into the concrete surround every 10 [254]. Channels shall weigh less than 11.4 lbs. [5.2 kg] per linear foot, have smooth 6.5 [165] radiused self cleaning bottom with a Manning's coefficient of 0.009 and 1.00% or neutral 0% built-in slope. Channels are available with inverts ranging from 11.25 [286] to 36.21 [920]. Channel shall have all grates locked down. Channels come with clips attached to the frame to accommodate vertical re-bar for positioning and anchoring purposes. Shall be provided with the standard GDC grate, Zurn 25-1/2 [648] wide Galvanized Ductile Iron Slotted Grate, and lock down to the frame with 4 contiguous bolt anchors per grate. Ductile Iron conforms to ASTM specification A536-84, Grade 80-55-06, and Galvanizing conforms to ASTM specification A123. Ductile Iron grate is rated class C per the DIN EN1433 top load classifications. Supplied in 20 [508] nominal lengths with 1-1/32 [26] wide slots, and 1-3/4 [44] bearing depth. Grate has an open area of 133 sq. in. per ft. [281530 sq. mm per meter]. The 1/4 [6] thick Galvanized Carbon Steel Frame Assembly conforms to ASTM specification A36, and Galvanizing conforms to ASTM specification A123, with 10 - 4 [102] long concrete anchors per 80 [2032]. All welds must be performed by a certified welder per ASTM standard AWS D1.1. Frames shall be produced in the USA.

**PREFIX**

\_\_\_ Z 80 [2032] High Density Polyethylene Channel, Heavy-Duty Galvanized Frame with Anchor Studs\*

**SUFFIX OPTIONS** (Check/specify appropriate options)

**Adapters**

- \_\_\_ -E1 Closed End Cap
- \_\_\_ -E4 4 [102] No-Hub End Outlet
- \_\_\_ -E6 6 [152] No-Hub End Outlet
- \_\_\_ -E8 8 [203] No-Hub End Outlet
- \_\_\_ -E12 12 [305] No-Hub End Outlet
- \_\_\_ -E18 18 [457] No-Hub End Outlet
- \_\_\_ -U4 4 [102] No-Hub Bottom Outlet
- \_\_\_ -U6 6 [152] No-Hub Bottom Outlet
- \_\_\_ -U8 8 [203] No-Hub Bottom Outlet
- \_\_\_ -U12 12 [305] No-Hub Bottom Outlet
- \_\_\_ -U18 18 [457] No-Hub Bottom Outlet

**Grate Options (Load Classifications are per DIN EN1433)**

- \_\_\_ -DCC Ductile Iron Solid Cover - Class C
- \_\_\_ -DGC Ductile Iron Slotted Grate - Class C\*
- \_\_\_ -DGF Ductile Iron Slotted Grate - Class F
- \_\_\_ -GDC Galvanized Ductile Iron Grate - Class C
- \_\_\_ -GDF Galvanized Ductile Iron Grate - Class F
- \_\_\_ -HPD Heel-Proof Longitudinal Ductile Iron Grate - Class C

**MADE in the U.S.A.** (Load Classifications are per DIN EN1433)

- \_\_\_ -DGE-USA Ductile Iron Slotted Grate - Class E
- \_\_\_ -GDE-USA Galvanized Ductile Slotted Grate - Class E

**MADE in the U.S.A. Miscellaneous Options**

- \_\_\_ -VP Vandal-Proof Lockdown

\*REGULARLY FURNISHED UNLESS OTHERWISE SPECIFIED

Trench #	'A' Shallow In.	'B' Deep Inv.	Flow		
			(gpm)	(lps)	(cfs)
2101P	11.250 [286]	12.082 [307]	3734	236	8.369
2102P	12.082 [307]	12.914 [328]	4398	277	9.857
2103P	12.914 [328]	13.746 [349]	5081	320	11.388
2104P	13.746 [349]	14.578 [370]	5779	365	12.953
2105P	14.578 [370]	15.410 [391]	6491	409	14.549
2105NP	15.410 [391]	15.410 [391]	-	-	-
2106P	15.410 [391]	16.242 [413]	7214	455	16.170
2107P	16.242 [413]	17.074 [434]	7948	501	17.814
2108P	17.074 [434]	17.906 [455]	8690	548	19.478
2109P	17.906 [455]	18.738 [476]	9440	595	21.159
2110P	18.738 [476]	19.570 [497]	10197	643	22.855
2111P	19.570 [497]	20.402 [518]	10960	691	24.565
2112P	20.402 [518]	21.234 [539]	11728	740	26.287
2113P	21.234 [539]	22.066 [560]	12501	789	28.020
2114P	22.066 [560]	22.898 [582]	13279	838	29.763
2115P	22.898 [582]	23.730 [603]	14060	887	31.514
2115NP	23.730 [603]	23.730 [603]	-	-	-
2116P	23.730 [603]	24.562 [624]	14845	936	33.274
2117P	24.562 [624]	25.394 [645]	15633	986	35.041
2118P	25.394 [645]	26.226 [666]	16424	1036	36.814
2119P	26.226 [666]	27.058 [687]	17218	1086	38.594
2120P	27.058 [687]	27.890 [708]	18015	1136	40.379
2121P	27.890 [708]	28.722 [730]	18814	1187	42.169
2122P	28.722 [730]	29.554 [751]	19614	1237	43.964
2123P	29.554 [751]	30.386 [772]	20417	1288	45.763
2124P	30.386 [772]	31.218 [793]	21222	1339	47.567
2125P	31.218 [793]	32.050 [814]	22028	1390	49.374
2125NP	32.050 [814]	32.050 [814]	-	-	-
2126P	32.050 [814]	32.882 [835]	22836	1440	51.184
2127P	32.882 [835]	33.714 [856]	23645	1492	52.998
2128P	33.714 [856]	34.546 [877]	24455	1543	54.815
2129P	34.546 [877]	35.378 [899]	25267	1594	56.634
2130P	35.378 [899]	36.210 [920]	26080	1645	58.457

(Neutral channels available for all section numbers)

REV. - DATE: 3/14/11 C.N. NO. 120432  
DWG. NO. 303412 PRODUCT NO. Z874-21-HDG