



Model(s) Z871J3-XL

AquaSpec® kitchen sink faucet with 9-1/2" tubular spout and dome lever handles

TAG

Architectural/Engineering Specification:

Polished chrome-plated 8" [203mm] brass deck faucet with a 9-1/2" [241mm] tubular brass swing spout and quarter turn ceramic disc cartridges. Unit is furnished with a 2.2 GPM [8.3 L] pressure compensating aerator (complying with ANSI A112.18.1 Standard for flow), 2" [51mm] vandal-resistant color-coded metal dome lever handles, mounting hardware and 1/2" NPSM coupling nuts for standard lavatory risers.

Zurn Lead Free products (-XL), is the line of durable, high quality brass faucets and fixtures that are designed and manufactured to comply with state laws and local codes that mandate lead content levels. Zurn Lead Free products (-XL) are manufactured with less than one quarter of one percent (0.25%) total lead content by weighted average.

PRODUCT FEATURES:

- Ceramic Disc Cartridge
- Chrome-plated Cast Brass Body
- 2" vandal resistant color coded metal dome lever handles

SUFFIX OPTIONS:

<input type="checkbox"/> -HS	Hose and Spray
------------------------------	----------------

AERATOR OPTIONS:

	Suffix	Flowrate GPM [L]	Vandal- Resistant	Pressure Compensating	Outlet Type
<input type="checkbox"/>	-16F	1.0 GPM [3.8L]	x	x	Spray
<input type="checkbox"/>	-17F	1.5 GPM [5.7L]	x	x	Aerator
<input type="checkbox"/>	-18F	1.5 GPM [5.7L]	x	x	Laminar
<input type="checkbox"/>	-22F	1.0 GPM [3.8L]	x		Laminar
<input type="checkbox"/>	-25F	0.35 GPM [1.3L]	x	x	Spray
<input type="checkbox"/>	-27F	0.5 GPM [1.9L]			Laminar
<input type="checkbox"/>	-28F	0.5 GPM [1.9L]	x		Laminar
<input type="checkbox"/>	-2F	2.2 GPM [8.3L]	x		Aerator
<input type="checkbox"/>	-3F	0.5 GPM [1.9L]	x		Spray
<input type="checkbox"/>	-4F	2.2 GPM [8.3L]	x		Laminar
<input type="checkbox"/>	-7F	1.0 GPM [3.8L]		x	Spray



Product Compliance:

ADA
ASME A112.18.1/CSA B125.1
CSA B125.1

*Complies with ADA & ICC A117.1 accessibility requirements when installed according to the requirements outlined in these standards.

**Although products with certain combinations of options and features will meet or comply with these standards and/or certifications, not every combination of options and features will result in such compliance. If you have any questions about your particular product, please contact our Customer Care Dept. at 1-855-ONE-ZURN (United States) or 1-877-892-5216 (Canada) for confirmation.*

[Installation Guide - CF1192.pdf](#)

Architectural/Engineering Approval

Design and dimensional data (inches and [mm]) are subject to manufacturing tolerances and change without notice.

⚠ WARNING: Cancer and Reproductive Harm – www.P65warnings.ca.gov
 ⚠ ADVERTENCIA: Cáncer y daño reproductivo – www.P65warnings.ca.gov
 ⚠ AVERTISSEMENT: Cancer et effets néfastes sur la reproduction – www.P65warnings.ca.gov



Model(s) Z871J3-XL

AquaSpec® kitchen sink faucet with 9-1/2" tubular spout and dome lever handles

TAG

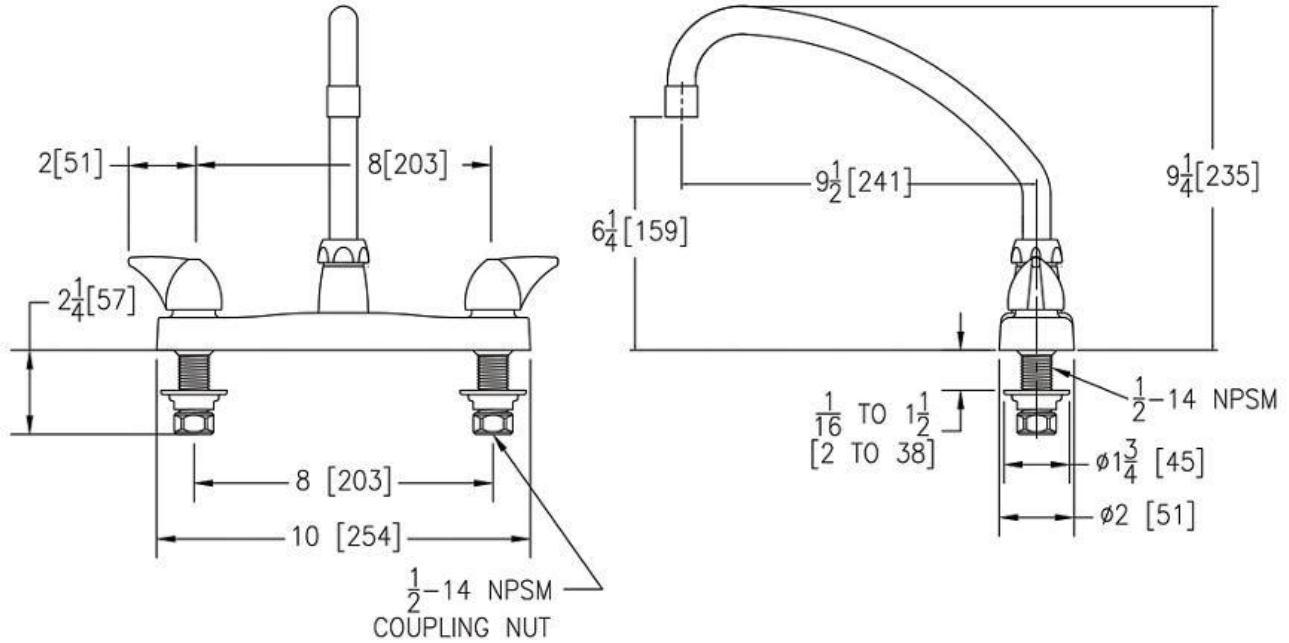

NOTE: All dimensions are for reference only. Do not use for pre-plumbing.

Design and dimensional data (inches and [mm]) are subject to manufacturing tolerances and change without notice.

⚠ WARNING: Cancer and Reproductive Harm - www.P65warnings.ca.gov

⚠ ADVERTENCIA: Cáncer y daño reproductivo - www.P65warnings.ca.gov

⚠ AVERTISSEMENT: Cancer et effets néfastes sur la reproduction - www.P65warnings.ca.gov