



Model(s) Z843X1-XL

AquaSpec® wall-mount pre-rinse unit with 24" riser and 36" spray hose

TAG _____

Architectural/Engineering Specification:

Polished chrome plated cast brass 8" [203mm] pre-rinse faucet with quarter turn ceramic disc cartridges, 3/8" [10mm] short swivel inlets providing adjustable centers from 7-1/4" [184mm] to 8-3/4" [222mm], integral service stops, check stops and 2-1/2" [64mm] vandal resistant color-coded metal lever handles. Unit is furnished with a 24" [610mm] riser, a 36" [914mm] stainless steel spring hose, a self-closing 1.6 GPM @ 60 psi (6.1 l/min. @ 400 kPa) pre-rinse hand held valve with an insulated 6" [152mm] handle, a stay open clip, a pipe support and a hook.

PRODUCT FEATURES:

- Ceramic Disc Cartridge
- Chrome-plated Cast Brass Body
- 2-1/2" Vandal-Resistant Color-Coded Metal Lever Handles



**Although products with certain combinations of options and features will meet or comply with these standards and/or certifications, not every combination of options and features will result in such compliance. If you have any questions about your particular product, please contact our Customer Care Dept. at 1-855-ONE-ZURN (United States) or 1-877-892-5216 (Canada) for confirmation.*

Architectural/Engineering Approval

Design and dimensional data (inches and [mm]) are subject to manufacturing tolerances and change without notice.

⚠ WARNING: Cancer and Reproductive Harm – www.P65warnings.ca.gov

⚠ ADVERTENCIA: Cáncer y daño reproductivo – www.P65warnings.ca.gov

⚠ AVERTISSEMENT: Cancer et effets néfastes sur la reproduction – www.P65warnings.ca.gov

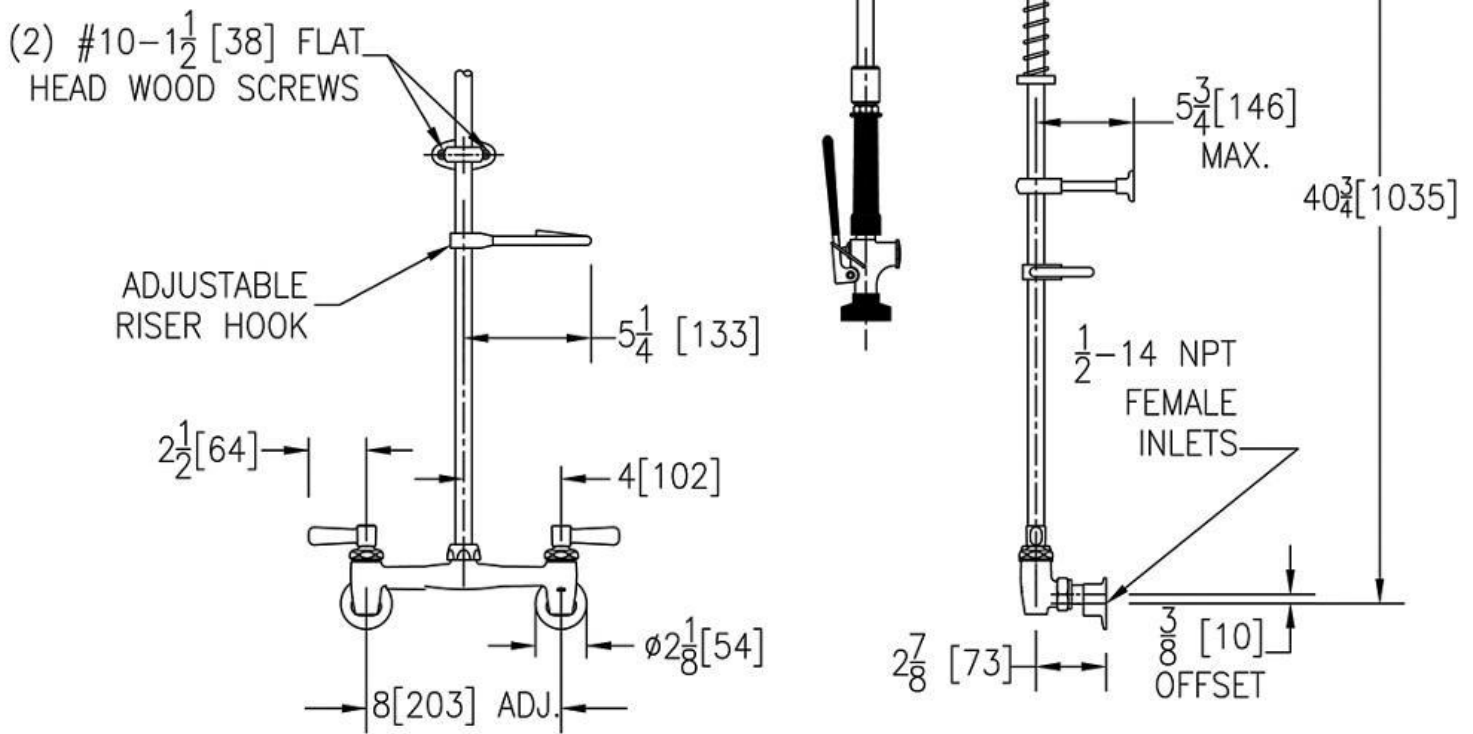

NOTE: All dimensions are for reference only. Do not use for pre-plumbing.

Design and dimensional data (inches and [mm]) are subject to manufacturing tolerances and change without notice.

⚠ WARNING: Cancer and Reproductive Harm - www.P65warnings.ca.gov
 ⚠ ADVERTENCIA: Cáncer y daño reproductivo - www.P65warnings.ca.gov
 ⚠ AVERTISSEMENT: Cancer et effets néfastes sur la reproduction - www.P65warnings.ca.gov