



Model(s) Z842H1-XL

AquaSpec® wall-mount sink faucet with 12" tubular spout and 2-1/2" lever handles (lead free)

TAG

Architectural/Engineering Specification:

Polished chrome-plated cast brass 8" sink faucet with quarter turn ceramic disc cartridges, 3/8" short swivel inlets providing adjustable centers from 7-1/4" to 8-3/4" with a 5" extension and a 12" tubular spout. Unit is furnished with vandal-resistant color-coded handles.

Zurn Lead Free products (-XL) is the line of durable, high quality brass faucets and fixtures that are designed and manufactured to comply with Section 1417 of the Safe Drinking Water Act (SDWA) which mandates the weighted average lead content of no more than 0.25% of the wetted surface.

PRODUCT FEATURES:

- Ceramic Disc Cartridge
- Chrome-plated Cast Brass Body
- 2-1/2" Vandal Resistant color coded metal lever handles
- Adjustable centers from 7-1/4" to 8-3/4"

AERATOR OPTIONS:

	Suffix	Flowrate GPM [L]	Vandal- Resistant	Pressure Compensating	Outlet Type
<input type="checkbox"/>	-16F	1.0 GPM [3.8L]	x	x	Spray
<input type="checkbox"/>	-17F	1.5 GPM [5.7L]	x	x	Aerator
<input type="checkbox"/>	-18F	1.5 GPM [5.7L]	x	x	Laminar
<input type="checkbox"/>	-22F	1.0 GPM [3.8L]	x		Laminar
<input type="checkbox"/>	-25F	0.35 GPM [1.3L]	x	x	Spray
<input type="checkbox"/>	-27F	0.5 GPM [1.9L]			Laminar
<input type="checkbox"/>	-28F	0.5 GPM [1.9L]	x		Laminar
<input type="checkbox"/>	-2F	2.2 GPM [8.3L]	x		Aerator
<input type="checkbox"/>	-3F	0.5 GPM [1.9L]	x		Spray
<input type="checkbox"/>	-4F	2.2 GPM [8.3L]	x		Laminar
<input type="checkbox"/>	-7F	1.0 GPM [3.8L]		x	Spray



Product Compliance:

ADA
 ASME A112.18.1/CSA B125.1
 CSA B125.1
 IPC
 NSF 372

*Complies with ADA & ICC A117.1 accessibility requirements when installed according to the requirements outlined in these standards.

**Although products with certain combinations of options and features will meet or comply with these standards and/or certifications, not every combination of options and features will result in such compliance. If you have any questions about your particular product, please contact our Customer Care Dept. at 1-855-ONE-ZURN (United States) or 1-877-892-5216 (Canada) for confirmation.*

[Installation Guide - CF1202.pdf](#)

Architectural/Engineering Approval

Design and dimensional data (inches and [mm]) are subject to manufacturing tolerances and change without notice.

⚠ WARNING: Cancer and Reproductive Harm – www.P65warnings.ca.gov
 ⚠ ADVERTENCIA: Cáncer y daño reproductivo – www.P65warnings.ca.gov
 ⚠ AVERTISSEMENT: Cancer et effets néfastes sur la reproduction – www.P65warnings.ca.gov



Model(s) Z842H1-XL

AquaSpec® wall-mount sink faucet with 12" tubular spout and 2-1/2" lever handles (lead free)

TAG

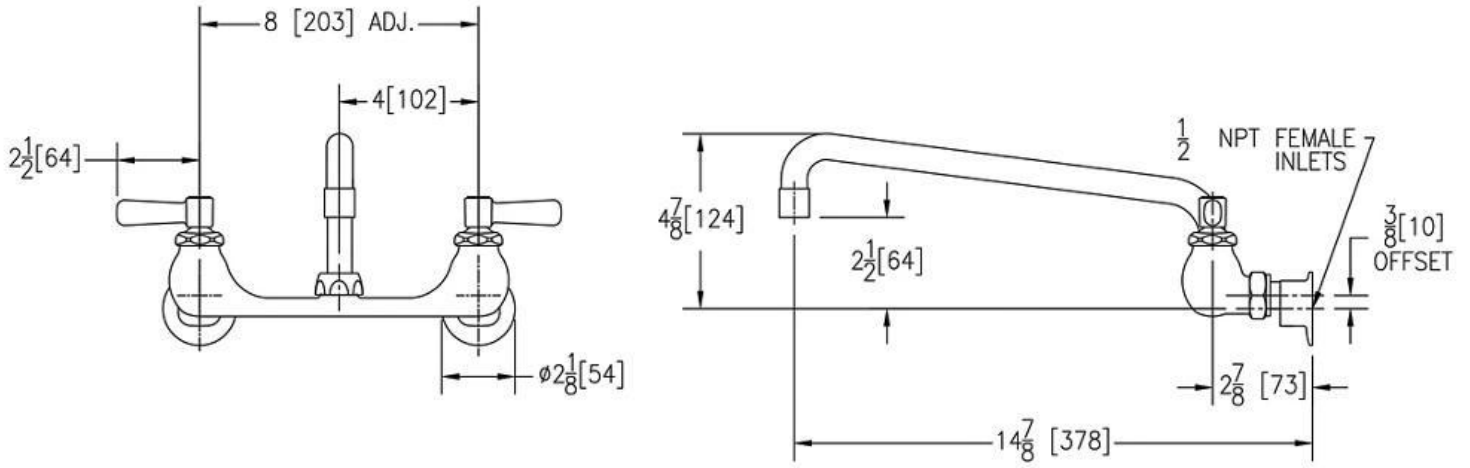

NOTE: All dimensions are for reference only. Do not use for pre-plumbing.

Design and dimensional data (inches and [mm]) are subject to manufacturing tolerances and change without notice.

⚠ WARNING: Cancer and Reproductive Harm - www.P65warnings.ca.gov
⚠ ADVERTENCIA: Cáncer y daño reproductivo - www.P65warnings.ca.gov
⚠ AVERTISSEMENT: Cancer et effets néfastes sur la reproduction - www.P65warnings.ca.gov