



Model(s) Z831A2-XL

AquaSpec® widespread faucet with 3-1/2" gooseneck and cross handles

TAG _____

Architectural/Engineering Specification:

Polished chrome-plated widespread with adjustable centers from 6"[152mm] to 20"[508mm], a 3-1/2"[89mm] centerline rigid or swing gooseneck spout and quarter turn ceramic disc cartridges. Unit is furnished with a 2.2 GPM [8.3 L] pressure compensating aerator (complying with ANSI A112.18.1 Standard for flow), vandal-resistant color-coded metal four arm handles, mounting hardware and 1/2" NPSM coupling nuts for standard lavatory risers. Widespread accommodates installations up to 1-1/8"[29mm] thick.

Zurn Lead Free products (-XL), is the line of durable, high quality brass faucets and fixtures that are designed and manufactured to comply with state laws and local codes that mandate lead content levels. Zurn Lead Free products (-XL) are manufactured with less than one quarter of one percent (0.25%) total lead content by weighted average.

PRODUCT FEATURES:

- Ceramic Disc Cartridge
- Chrome-plated Cast Brass Body
- Widespread Handles Adjustable From 6" to 20" Centers
- Vandal resistant color coded 4 arm handles

SUFFIX OPTIONS:

<input type="checkbox"/>	-G	1-1/4" [32mm] Grid Strainer Drain
<input type="checkbox"/>	-HS	Hose and Spray
<input type="checkbox"/>	-ICT	Inter-connecting Copper Supply Tubes for 8" In-line Centers
<input type="checkbox"/>	-P	1-1/4" [32mm] Pop-up Drain

AERATOR OPTIONS:

	Suffix	Flowrate GPM [L]	Vandal- Resistant	WaterSense* Labeled	Pressure Compensating	Outlet Type
<input type="checkbox"/>	-16F	1.0 GPM [3.8L]	x		x	Spray
<input type="checkbox"/>	-17F	1.5 GPM [5.7L]	x	x	x	Aerator
<input type="checkbox"/>	-18F	1.5 GPM [5.7L]	x	x	x	Laminar
<input type="checkbox"/>	-22F	1.0 GPM [3.8L]	x			Laminar
<input type="checkbox"/>	-25F	0.35 GPM [1.3L]	x		x	Spray
<input type="checkbox"/>	-27F	0.5 GPM [1.9L]				Laminar
<input type="checkbox"/>	-28F	0.5 GPM [1.9L]	x			Laminar
<input type="checkbox"/>	-2F	2.2 GPM [8.3L]	x			Aerator
<input type="checkbox"/>	-3F	0.5 GPM [1.9L]	x			Spray
<input type="checkbox"/>	-4F	2.2 GPM [8.3L]	x			Laminar
<input type="checkbox"/>	-7F	1.0 GPM [3.8L]		x	x	Spray
<input type="checkbox"/>	-FC0.5	0.5 GPM [1.9L]			x	
<input type="checkbox"/>	-FC1.0	1.0 GPM [3.8L]			x	
<input type="checkbox"/>	-FC1.5	1.5 GPM [5.7L]			x	
<input type="checkbox"/>	-FC2.0	2.0 GPM [7.6L]			x	



Product Compliance:

ASME A112.18.1/CSA B125.1
CEC
CSA B125.1
NSF 61

**Although products with certain combinations of options and features will meet or comply with these standards and/or certifications, not every combination of options and features will result in such compliance. If you have any questions about your particular product, please contact our Customer Care Dept. at 1-855-ONE-ZURN (United States) or 1-877-892-5216 (Canada) for confirmation.*

[Installation Guide - CF1197.pdf](#)

Architectural/Engineering Approval

Design and dimensional data (inches and [mm]) are subject to manufacturing tolerances and change without notice.

⚠ WARNING: Cancer and Reproductive Harm – www.P65warnings.ca.gov
 ⚠ ADVERTENCIA: Cáncer y daño reproductivo – www.P65warnings.ca.gov
 ⚠ AVERTISSEMENT: Cancer et effets néfastes sur la reproduction – www.P65warnings.ca.gov

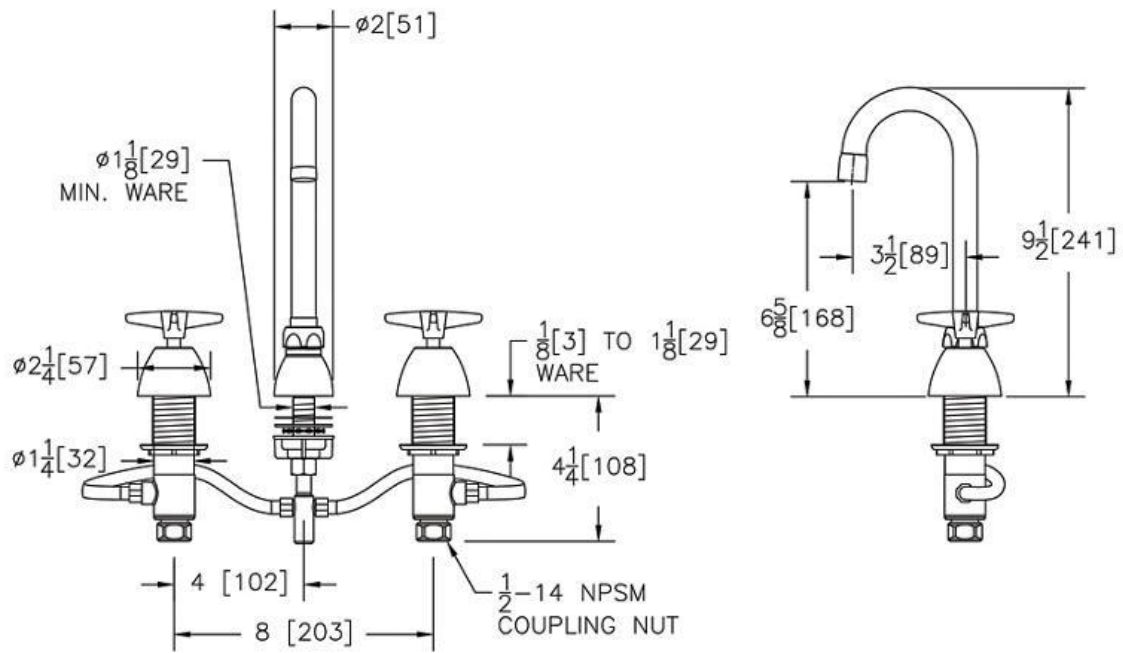

NOTE: All dimensions are for reference only. Do not use for pre-plumbing.