



Model(s) Z812U3-XL

AquaSpec® centerset 6" hi-rise vacuum breaker spout with dome lever handles

TAG

Architectural/Engineering Specification:

Polished chrome-plated cast brass faucet body with integral shanks, quarter turn ceramic disc cartridges and a 6" [152mm] centerline rigid gooseneck spout with vacuum breaker. Unit is furnished with a 2.2 GPM [8.3 L] pressure compensating aerator (complying with ANSI A112.18.1 Standard for flow), 2" [51mm] vandal-resistant color-coded metal dome lever handles, mounting hardware and 1/2" NPSM coupling nuts for standard lavatory risers.

PRODUCT FEATURES:

- Heavy-duty quarter turn ceramic disc cartridge
- Chrome-plated cast brass body with integral shanks
- Vandal-resistant color coded dome lever handles

SUFFIX OPTIONS:

<input type="checkbox"/>	-G	1-1/4" [32mm] Grid Strainer Drain
<input type="checkbox"/>	-P	1-1/4" [32mm] Pop-up Drain

AERATOR OPTIONS:

	Suffix	Flowrate GPM [L]	Vandal- Resistant	Pressure Compensating	Outlet Type
<input type="checkbox"/>	-16F	1.0 GPM [3.8L]	x	x	Spray
<input type="checkbox"/>	-17F	1.5 GPM [5.7L]	x	x	Aerator
<input type="checkbox"/>	-18F	1.5 GPM [5.7L]	x	x	Laminar
<input type="checkbox"/>	-22F	1.0 GPM [3.8L]	x		Laminar
<input type="checkbox"/>	-25F	0.35 GPM [1.3L]	x	x	Spray
<input type="checkbox"/>	-28F	0.5 GPM [1.9L]	x		Laminar
<input type="checkbox"/>	-2F	2.2 GPM [8.3L]	x		Aerator
<input type="checkbox"/>	-3F	0.5 GPM [1.9L]	x		Spray
<input type="checkbox"/>	-4F	2.2 GPM [8.3L]	x		Laminar
<input type="checkbox"/>	-7F	1.0 GPM [3.8L]		x	Spray
<input type="checkbox"/>	-27F	0.5 GPM [1.9L]			Laminar



Product Compliance: ADA

*Complies with ADA & ICC A117.1 accessibility requirements when installed according to the requirements outlined in these standards.

**Although products with certain combinations of options and features will meet or comply with these standards and/or certifications, not every combination of options and features will result in such compliance. If you have any questions about your particular product, please contact our Customer Care Dept. at 1-855-ONE-ZURN (United States) or 1-877-892-5216 (Canada) for confirmation.*

[Installation Guide - cf98.pdf](#)

Architectural/Engineering Approval

Design and dimensional data (inches and [mm]) are subject to manufacturing tolerances and change without notice.

⚠ WARNING: Cancer and Reproductive Harm – www.P65warnings.ca.gov
 ⚠ ADVERTENCIA: Cáncer y daño reproductivo – www.P65warnings.ca.gov
 ⚠ AVERTISSEMENT: Cancer et effets néfastes sur la reproduction – www.P65warnings.ca.gov



Model(s) Z812U3-XL

AquaSpec® centerset 6" hi-rise vacuum breaker spout with dome lever handles

TAG

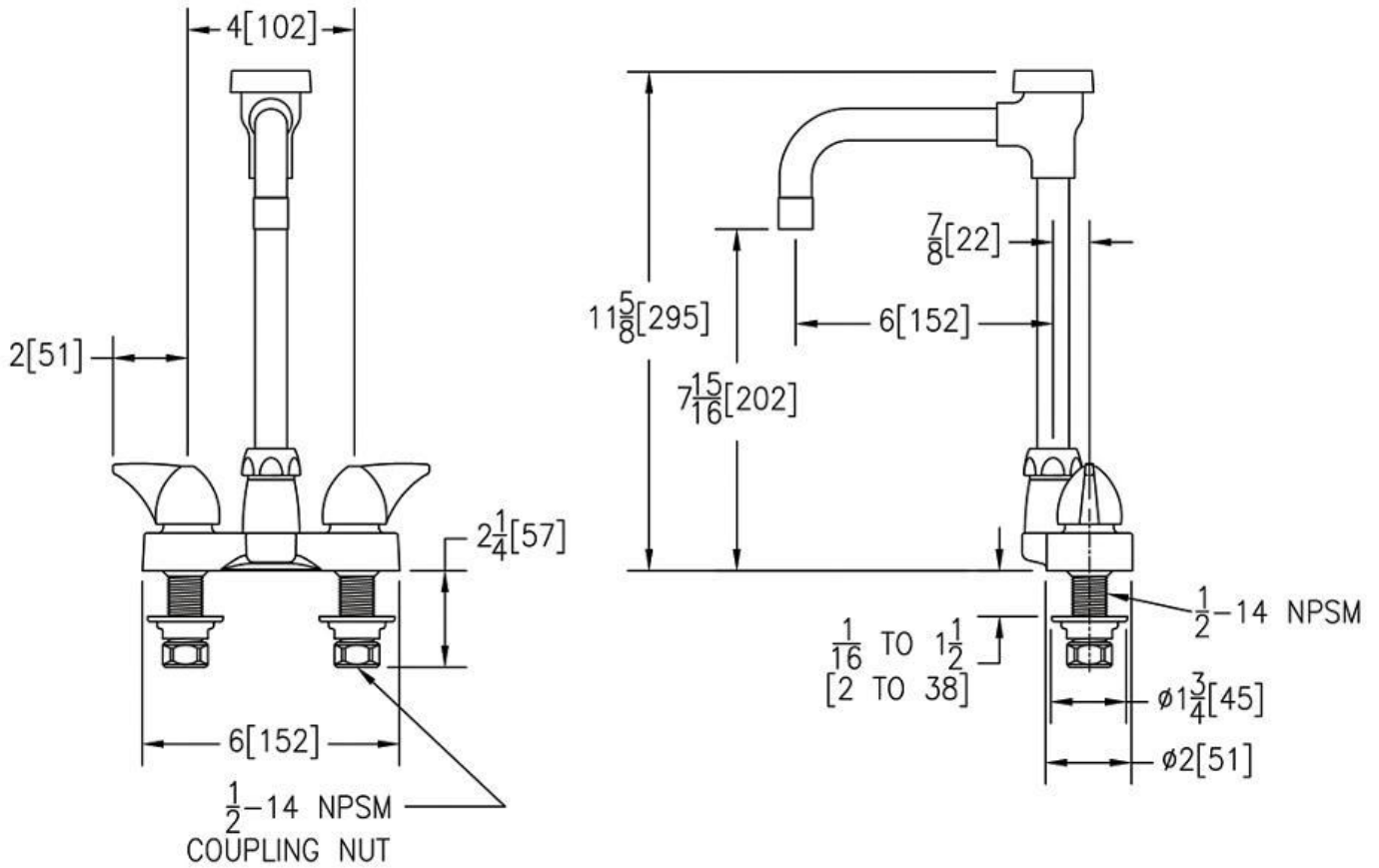

NOTE: All dimensions are for reference only. Do not use for pre-plumbing.

Design and dimensional data (inches and [mm]) are subject to manufacturing tolerances and change without notice.

⚠ WARNING: Cancer and Reproductive Harm - www.P65warnings.ca.gov
 ⚠ ADVERTENCIA: Cáncer y daño reproductivo - www.P65warnings.ca.gov
 ⚠ AVERTISSEMENT: Cancer et effets néfastes sur la reproduction - www.P65warnings.ca.gov