



Z548

15 [381] DIAMETER HEAVY-DUTY DRAIN WITH INTEGRAL TRAP & CLEANOUT

SPECIFICATION SHEET

TAG _____

Dimensional Data (inches and [mm]) are Subject to Manufacturing Tolerances and Change Without Notice

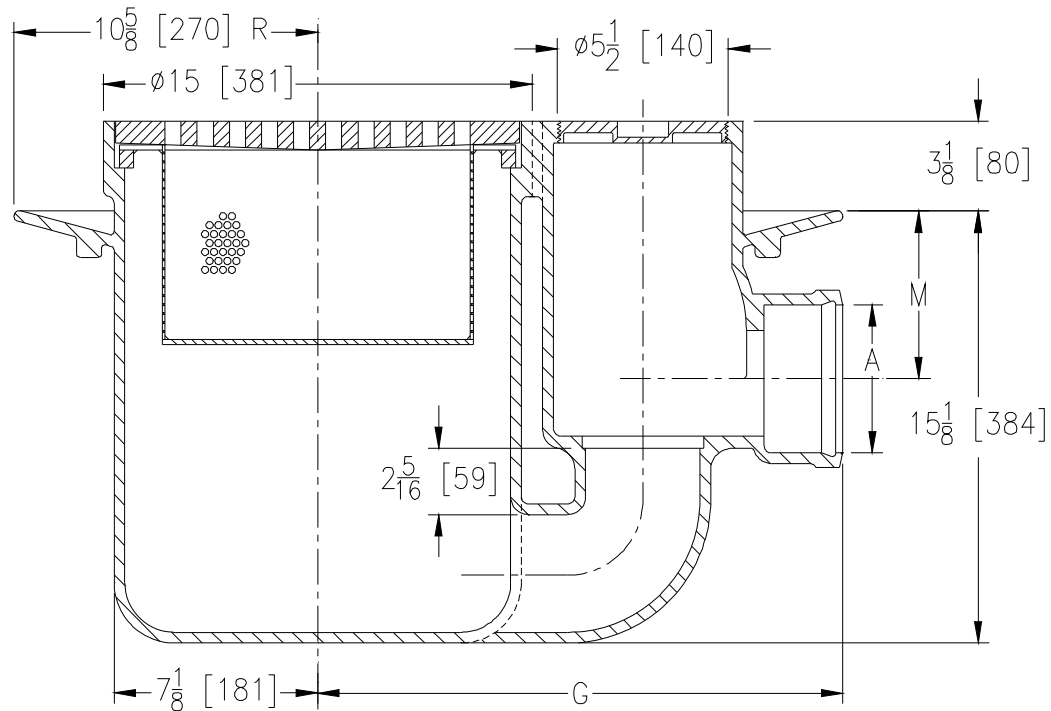

Dimensions In Inches			Approx. Wt. Lbs. [kg]	Grate Open Area Sq. In. [cm ²]
A - Pipe Size	G	M		
3 [76]	18 [457]	6-1/2 [165]	209 [95]	45 [290]
4 [102]	18-1/8 [460]	6 [152]		

ENGINEERING SPECIFICATION: ZURN Z548

15 [381] Diameter top drain, Dura-Coated body with integral double wall trap, side outlet with seepage pan and heavy-duty cast iron slotted grate complete with suspended sediment bucket and plain bronze floor level cleanout.

OPTIONS (Check/specify appropriate options)

PIPE SIZE

3-4 [76-102]

(Specify size/type) OUTLET

____ HB Hub

PREFIXES

- ____ Z Body and D.C.C.I. Top*
- ____ ZB Body with Polished Bronze Top (Add 3/16 [5] to 3 [76] Dim.)
- ____ ZN Body with Polished Nickel Bronze Top (Add 3/16 [5] to 3 [76] Dim.)

SUFFIXES

- ____ -AR Acid Resisting Epoxy Coated Cast Iron
- ____ -C Clamp Collar
- ____ -DG Duresist Grate
- ____ -G Galvanized Cast Iron
- ____ -V Backwater Valve
- ____ -YA Aluminum Sediment Bucket

* Regularly furnished unless otherwise specified.