



Z1854

12" x 12" [305 x 305] SQ. FLOOR SINK x 4" [102] DEEP W/
RESILIENT FLOORING ADJUSTABLE CLAMPING FLANGE,
TAPERED BOTTOM AND SEDIMENT BASKET

SPECIFICATION SHEET

TAG _____

Design and Dimensional Data (inches and [mm]) are Subject to Manufacturing Tolerances and Change Without Notice

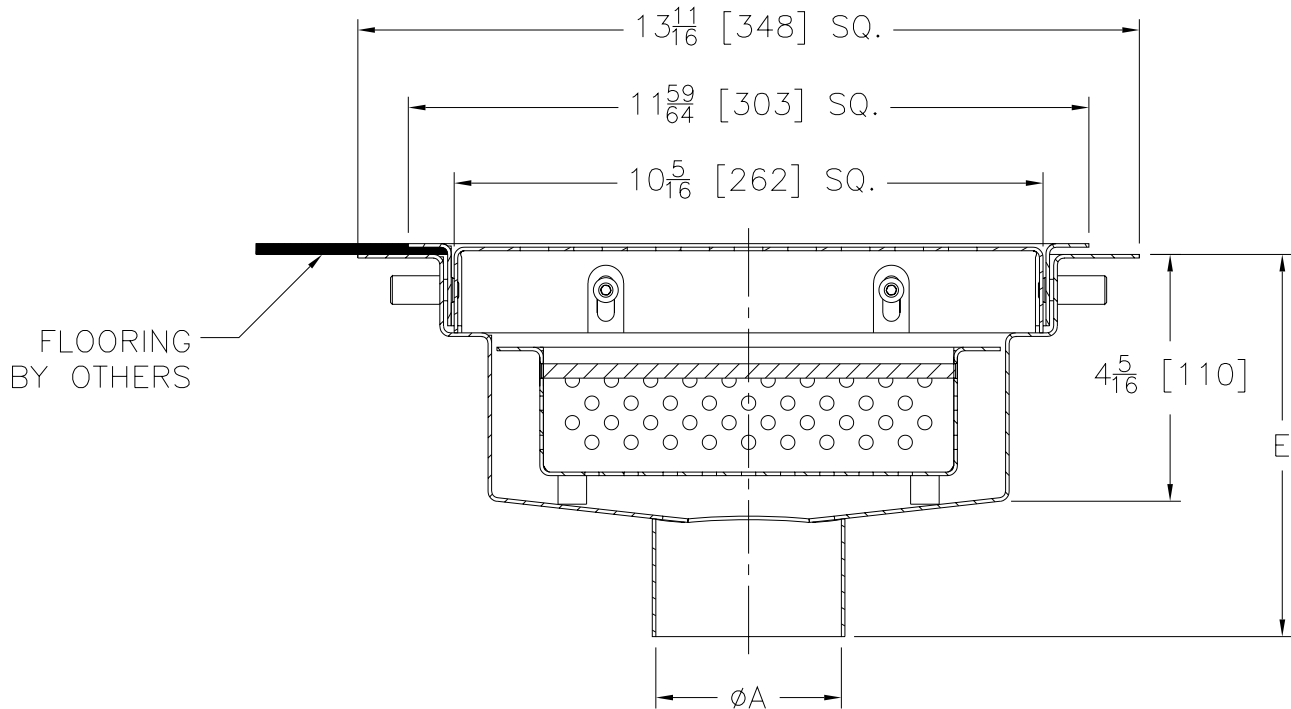

ENGINEERING SPECIFICATION: ZURN Z1854

12" [305mm] Square x 4" [102mm] deep, 16 gage, All Type 304 (CF8) Fabricated stainless steel light-duty floor sink with integral surface clamp for resilient flooring, 3/8" [10mm] sloped bottom from edge of body to the outlet, and non-tilt loose-set full grate with sediment basket for unlevel floor installations.

OPTIONS (Check/specify appropriate options)

PREFIXES

___ Z Type 304 (CF8) Stainless Steel Body*

___ ZM Type 316 (CF8M) Stainless Steel

PIPE SIZE

2, 3, 4 [51, 76, 102]

(Specify size/type) **OUTLET**

___ NH No-Hub

'E' BODY HT. DIM.

6-11/32 [161]

SUFFIXES

___ -G2 1/2 Grate

___ -G3 3/4 Grate

___ -P 1/2 [13] Trap Primer Connection

* Regularly furnished unless otherwise specified

⚠ WARNING: Cancer and Reproductive Harm - www.P65Warnings.ca.gov

⚠ ADVERTENCIA: Cáncer y daño reproductivo - www.P65Warnings.ca.gov

⚠ AVERTISSEMENT: Cancer et effets néfastes sur la reproduction - www.P65Warnings.ca.gov

Zurn Industries, LLC | Specification Drainage Operation
1801 Pittsburgh Avenue, Erie, PA 16502, Ph. 855.663.9876

In Canada | Zurn Industries Limited
7900 Goreway Drive, Unit 10, Brampton, Ontario L6T 5W6, Ph. 877.892.5216

www.zurn.com

Rev.	-
Date:	07/25/25
C.N. No.	146828
Prod. Dwg. No.	Z1854