

WILKINS® Model FCIS (Connected Flood Control System)

Reduced Pressure Principle Assembly w/Integral Relief Valve Monitor and Automatic ACV Shutoff

Application

The Flood Control Integrated System (FCIS) prevents flooding of a building, caused by the discharge from a catastrophically fouled Reduced Pressure Principle backflow preventer. The pre-wired FCIS package includes a Reduced Pressure Principle backflow Preventer and Monitor Switch with Zurn Connected Endpoint Controller attached to a ZW206 Solenoid Control Valve to shut-off the water supply.



LEAD FREE

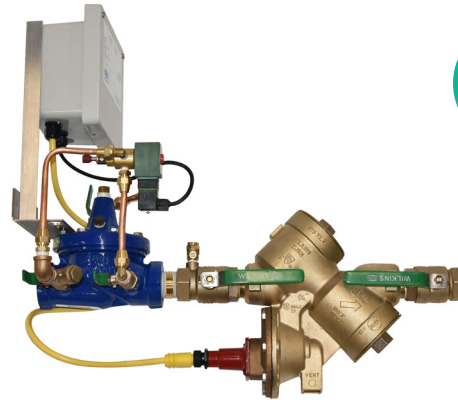

(Model FCIS Shown)

Standards Compliance

For compliance approvals reference spec sheets

For additional compliance approvals reference spec sheets

Sizes (1 1/4" - 2") 975XL2

Sizes (1 1/4" - 2") ZW206

Features

- Model 975XL2 Reduced Pressure Backflow Preventer with Monitor Switch
- ZW206 Solenoid Control Valve, 24 VDC operation, Normally Open (water is on during power failure) A manual operator on the solenoid is provided to operate the valve during power failure
- Zurn Connected Endpoint Control Box

Sizes: 1 1/4", 1 1/2", 2"

Maximum working water pressure 175 PSI

Maximum working water temperature 140°F

Hydrostatic test pressure 350 PSI

End connections (Threaded NPT) ANSI B1.20.1

Quick disconnect connectors

Alarm Output contacts

For additional component features reference spec sheet ZW206

CAUTION: To prevent water damage, an adequately sized drain MUST still be installed to handle water discharge from the backflow relief valve.

Options

(Suffixes can be combined)

- S - Threaded SXL Strainer Lead - Free
- AG - Air Gap Fitting
- C - Model 40XL2 for upstream to prevent water hammer discharge (1-1/4"-2")
- C - Model 40XL2 for downstream to prevent draining system (1-1/4" - 2")
- Solenoid Operation
- Normally Open (Opens on power failure)
- NC Normally Closed (Closes on power failure)
- RV - ACV Pilot Installed on Reverse Side

Relief Valve Discharge Rates

(Worst case condition- If 1st check or relief valve is lodged wide open)

Model 375, 475 & 975 RP & RPDA
Backflow Preventers

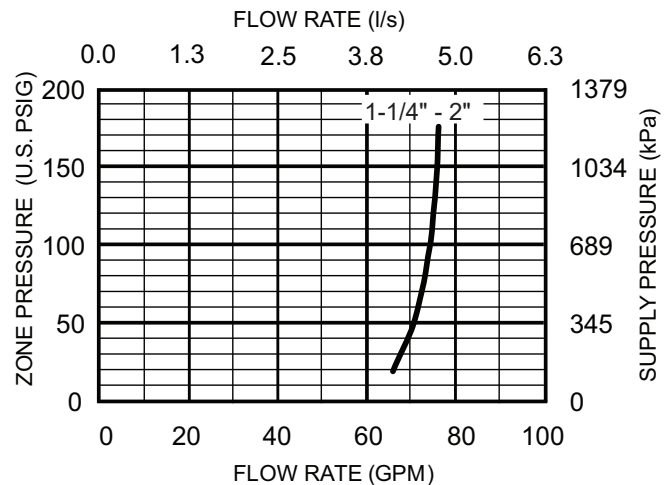

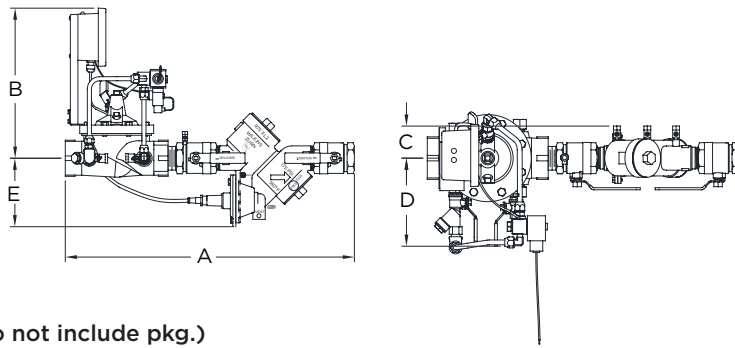

Dimensions & Weights (do not include pkg.)

MODEL FCIS SIZE	DIMENSION (approximate)												WEIGHT		
	A		B		B*		C		D		E				
	in.	mm	in.	mm	in.	mm	in.	mm	in.	mm	in.	mm	lbs.	kg	
1 1/4	32	24 9/16	624	16 1/2	419	20	508	3 1/2	89	7	178	6 3/4	171	47	21.3
1 1/2	40	25 1/16	637	16 1/2	419	20	508	3 1/2	89	7	178	6 3/4	171	47	21.3
2	50	28 9/16	725	16 13/16	427	20 1/3	516	3 1/2	89	7	178	6 3/4	171	60	27.2

This dimension is with position indicator on a ZW206

Installation

Modular system simplifies installation. Install ZW206 Solenoid Valve with Zurn Connected Endpoint Control Box on the water inlet. Install Model 975XL2 backflow preventer to outlet of solenoid valve. From the Zurn Connected Endpoint Control Box route the yellow cable to plug on the relief valve cover. Plug connector into monitor switch, screw lock ring into place and secure the cable to the assembly. Pressurize the system and ensure that it is stable. Provide 120 VAC power to Zurn Connected Endpoint Control Box and test operation per provided instructions. Local codes shall govern installation requirements. Unless otherwise specified, the assembly shall be mounted at a minimum of 12" (305mm) and a maximum of 30" (762mm) above adequate drains with sufficient side clearance for testing and maintenance. The installation shall be made so that no part of the unit can be submerged.

Typical Installation

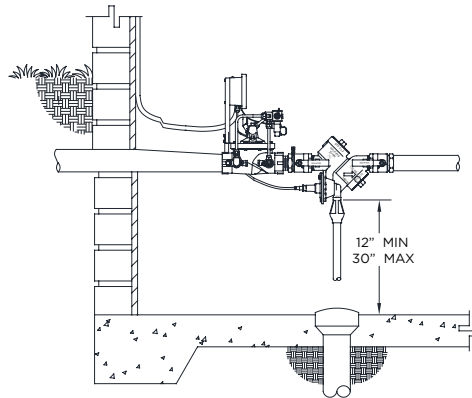

Single Water Shutdown

A single ZW206 Solenoid Control Valve to shutdown the water supply to the backflow preventer and system is our standard installation. This will prevent the discharge of water through a fouled first check in the static condition.

Specifications

The Flood Control Integrated System(FCIS) shall consist of a Reduced Pressure Principle Assembly (RP) (975XL2), a Solenoid Control Valve(SCV) (Model ZW206), and a Zurn Connected Endpoint Control Box and shall be constructed and tested at the factory as a complete assembly. The RP shall be certified to NSF/ANSI 61, and shall be ASSE 1013 Listed. The RP shall be furnished with full port, resilient seated shut-off valves, and shall be equipped with an integral Relief Valve Monitor Switch that monitors the Relief Valve in a closed position. The seat ring and the check valves shall be Noryl, the stems and springs shall be Stainless Steel, and the elastomers shall be EPDM. The SCV shall be a single seated, line-pressure-operated, diaphragm-actuated, pilot-controlled valve. The SCV shall seal by means of a corrosion resistant seat and a resilient, rectangular seat disc. The stem of the SCV shall be guided top and bottom by integral bushings, and shall contain no packing glands or stuffing boxes. The SCV shall be protected with internal and external FDA approved epoxy coating, and the diaphragm shall not be used as a seating surface. The Zurn Connected Endpoint Control Box shall have an input voltage of 120 VAC, and shall be provided with outputs of 24 VDC controlled by a user adjusted time delay relay. The Zurn Connected Endpoint Control Box shall be housed in a water-tight NEMA enclosure, and its outputs shall be configurable as either normally open or normally closed. The three components, the RP, SVC, and Zurn Connected Endpoint Control Box, when combined together, automatically shut off the water supply in the event of catastrophic relief valve discharge. The Reduced Pressure Principle Assembly, Solenoid Control Valve, and Zurn Connected Endpoint Control Box assembled as a complete unit shall be the Zurn Wilkins FCIS.

Job Name _____ **Contractor** _____
Job Location _____ **Engineer** _____